

## Features

- Economical solution to raise shower floors to accommodate wheel chairs
- Custom built to fit existing shower basins - rectangle shapes only
- Aluminum construction, will not rust
- Perforated surface allows water to drain through easily
- Surface contains strips of anti-slip traction tape
- UPS shippable

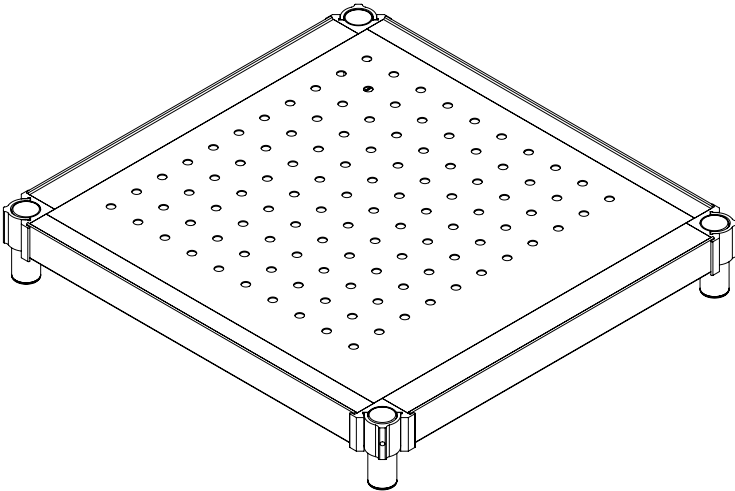
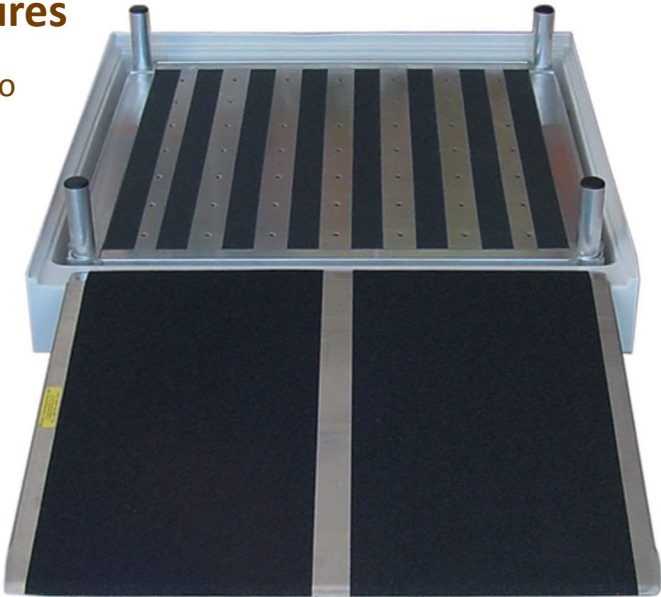

## Details and Specifications

- Durable lightweight aluminum
- Minimum height requirement is 2 1/8"
- PVI threshold ramp will be required to access shower platform (sold separately)

<b>Width</b>	Built to your specifications
<b>Length</b>	Built to your specifications
<b>Load Capacity</b>	400 lbs. on two axles
<b>Surface</b>	Slip resistant grooved aluminum

